

REVISIONS						
ZONE	LTR	DESCRIPTION	DATE	E.M.N.NO	DRAFT	CHKD
	Ø	ORIGINAL RELEASE FOR PRODUCTION	11-9-72			
	A	CHG. REF. DSG. T1 TO L12, T2 TO T1	11-30-72	20961	GE	
	B	VAL. CHG. L10, L11, C35, C30, C26, C24, R12, R13	2-2-72	21016	GE	

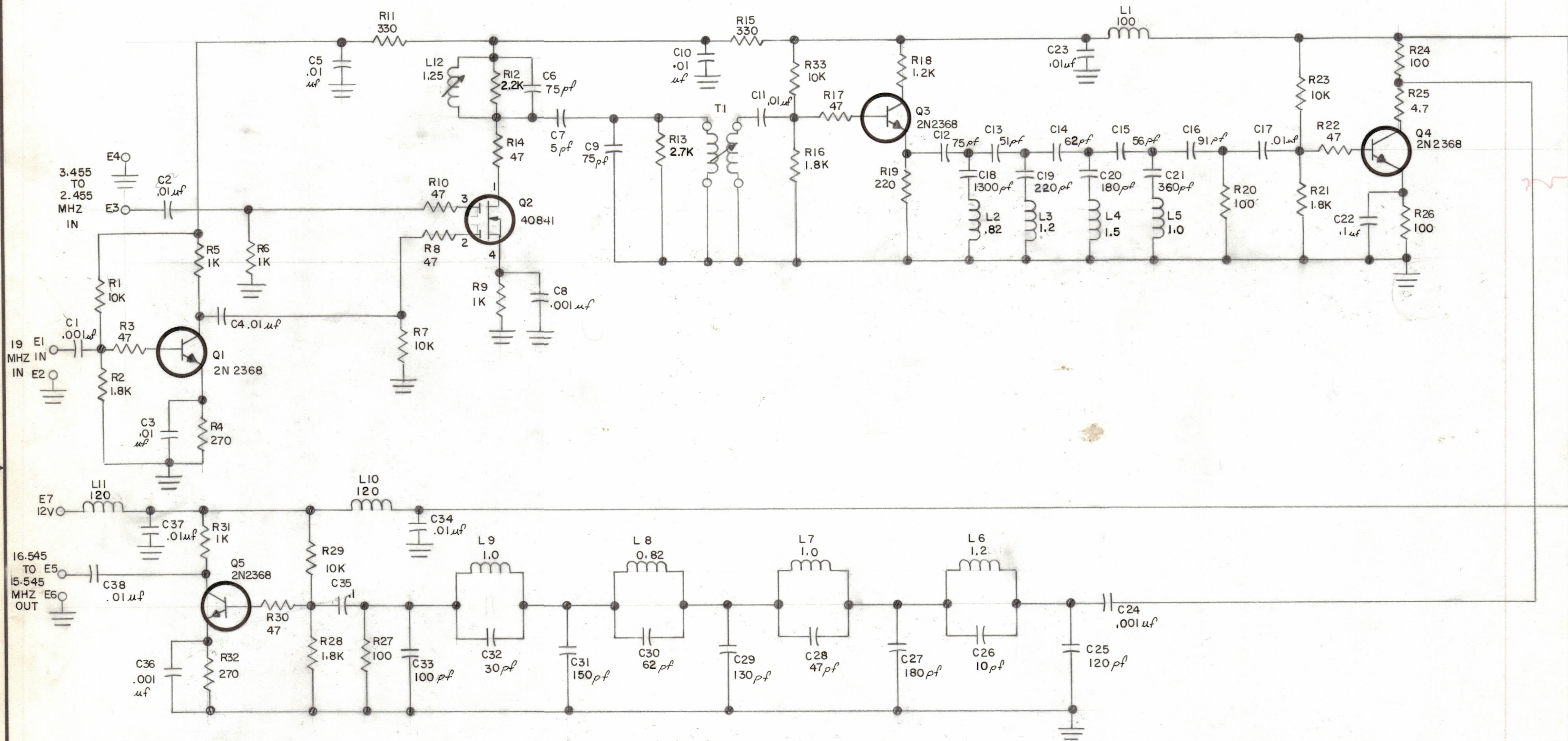

SYMBOL SERIES 800

MISSING SYMBOL	LAST SYMBOL
	C38
	E 7
	L12
	Q5
	R33
	T1

NOTE: UNLESS OTHERWISE SPECIFIED

RESISTORS IN OHMS (Ω) 1/4W
ALL INDUCTANCE VALUES IN MICROHENRIES

QTY / UNIT	MODEL USED ON	ASS'Y NO.
	RSU-1	
APPLICATION		
CODE		

NOTICE TO PERSONS RECEIVING THIS DRAWING
THE TECHNICAL MATERIEL CORPORATION claims proprietary right in the material disclosed hereon. This drawing is issued in confidence for engineering information only and may not be reproduced or used to manufacture anything shown hereon without permission from THE TECHNICAL MATERIEL CORPORATION to the user. This drawing is loaned for mutual assistance and is subject to recall at any time.

QTY. REQ.	ITEM	PART NO.	DESCRIPTION	SYMBOL
LIST OF MATERIAL				
FINAL APPROVAL: <i>[Signature]</i> DATE: 11-8-72 MECH. DES: <i>[Signature]</i> DATE: 11-8-72 ELECT. DES: <i>[Signature]</i> DATE: CHECKED: <i>[Signature]</i> DATE: DRAWN: GE DATE: 11/5/72				
THE TECHNICAL MATERIEL CORP. MAMARONECK, NEW YORK DIAGRAM SCHEMATIC SECOND MIXER				
SIZE	CODE IDENT. NO.	DWG NO.	ISSUE	
C	82679	CK1966	B	
SCALE	SHEET		OF	

CK1966

A

72